

**Gigabit Ethernet Switch
AE100922-001**

Users Manual

UM_001

Rev 1.0

March 2, 2009



1775 West Hibiscus Blvd, Suite 200
Melbourne, FL 32901
(321) 984-1671
WWW.AERONIX.COM

Table of Contents

1.	OVERVIEW	1
2.	BLOCK DIAGRAM	1
3.	ELECTRICAL CONNECTIONS.....	2
3.1.	J1 CONNECTOR.....	2
3.2.	J2 CONNECTOR.....	2
3.3.	TABLE 3-1: CONNECTOR PINOUTS	3
3.4.	INTERFACE PORT DETAILS.....	4
3.4.1.	<i>Ethernet Ports</i>	4
3.4.2.	<i>Serial and Programming Ports</i>	4
3.4.3.	<i>Input Power</i>	5
4.	PORT DETAILS	5
4.1.	SERIAL PORTS.....	5
4.2.	EXTERNAL PROGRAMMING PORT	5
5.	COMMAND LINE INTERFACE.....	7
5.1.	REQUIRED HARDWARE	7
5.2.	SERIAL PORT SETUP.....	7
5.3.	PROMPT	7
5.4.	MENUS	8
5.4.1.	<i>How the menus work</i>	8
5.4.2.	<i>Main Menu</i>	8
5.4.3.	<i>Reset Menu</i>	9
5.4.4.	<i>Configuration Menu</i>	10
5.5.	EXAMPLE	11
6.	SWITCH MANAGEMENT CAPABILITIES.....	13
7.	HARDWARE MOUNTING	14
8.	INDICATORS	14
9.	QUALIFICATIONS	16
10.	WARRANTY	17
11.	ACCESSORIES AND SERVICES	17

1. Overview

Designed and produced by Aeronix, Inc. of Melbourne, Florida, the Gigabit Ethernet Switch (GES) is intended for use in hostile military environments.

The GES is a lightly managed switch with twelve 10/100/1000BaseT ethernet ports, and two RS-232 management ports. Its rugged monolithic design is intended to operate in severe environments without the need for forced air cooling.

This document is intended to provide the information required to interface with the Aeronix Gigabit Ethernet Switch (GES) hardware.

The Part Number of the Aeronix 12-Port Gigabit Ethernet Switch is AE100922-001.

2. Block Diagram

The basic functional blocks within the GES and their basic interactions are shown in Figure 2-1.

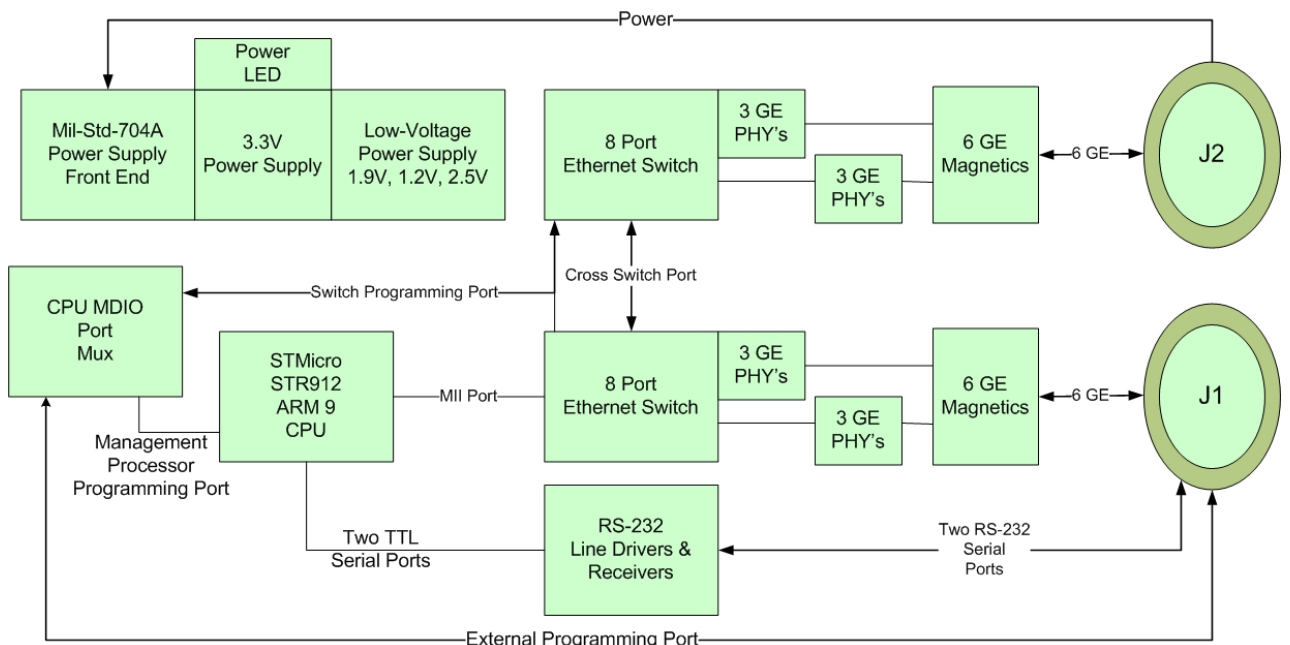

Figure 2-1: GES Block Diagram

3. Electrical Connections

The GES has two electrical connectors, J1 and J2.

3.1. J1 Connector

J1 is a 100 pin M38999 Series II connector, Part Number MS27508E22B35P.

An example mating cable connector for J1 is Part Number MS27473E22B35S.

J1 contains the following electrical interfaces:

- Six Ethernet Ports (0 – 5)
- Two RS-232 Serial Ports
 - DEV1 – Dedicated Maintenance Port for the Management Processor
 - DEV2 – Designed to be programmed as an Ethernet to Serial Bridge
- External Programming Port (SMI) for Switch IC Programming

3.2. J2 Connector

J2 is a 100 pin M38999 Series II connector Part Number MS27508E22B35PA.

An example mating cable connector for J2 is Part Number MS27473E22B35SA.

J2 contains the following electrical interfaces:

- Six Ethernet Ports (6 – 11)
- Input Power (nominal 28 VDC per MIL-STD-704A)



3.3. Table 3-1: Connector Pinouts

GES Connector Pinout							
J1				J2			
Pin	Signal	Pin	Signal	Pin	Signal	Pin	Signal
1	Chassis Ground	51	Chassis Ground	1	Chassis Ground	51	Chassis Ground
2	Port 0 - A(+)	52	Chassis Ground	2	Port 6 - A(+)	52	Chassis Ground
3	Port 0 - C(-)	53	Port 3 - A(+)	3	Port 6 - C(-)	53	Port 9 - A(+)
4	Port 0 - D(+)	54	Port 3 - C(+)	4	Port 6 - D(+)	54	Port 9 - C(+)
5	Port 0 - D(-)	55	Port 3 - D(-)	5	Port 6 - D(-)	55	Port 9 - D(-)
6	Chassis Ground	56	RX_FROM_DEV1	6	Chassis Ground	56	28VRTN
7	Port 1 - A(+)	57	TX_TO_DEV1	7	Port 7 - A(+)	57	28VRTN
8	Chassis Ground	58	Chassis Ground	8	Chassis Ground	58	Chassis Ground
9	Chassis Ground	59	Port 2 - B(+)	9	Chassis Ground	59	Port 8 - B(+)
10	Port 0 - A(-)	60	Port 2 - C(-)	10	Port 6 - A(-)	60	Port 8 - C(-)
11	Port 0 - C(+)	61	Port 2 - D(+)	11	Port 6 - C(+)	61	Port 8 - D(+)
12	Chassis Ground	62	Chassis Ground	12	Chassis Ground	62	Chassis Ground
13	Port 1 - A(-)	63	Port 3 - A(-)	13	Port 7 - A(-)	63	Port 9 - A(-)
14	Port 1 - C(+)	64	Chassis Ground	14	Port 7 - C(+)	64	Chassis Ground
15	Port 1 - D(-)	65	Chassis Ground	15	Port 7 - D(-)	65	Chassis Ground
16	Reserved	66	Chassis Ground	16	28V	66	Chassis Ground
17	Chassis Ground	67	RX_FROM_DEV2	17	Chassis Ground	67	28VRTN
18	Chassis Ground	68	TX_TO_DEV2	18	Chassis Ground	68	Reserved
19	Port 0 - B(+)	69	Chassis Ground	19	Port 6 - B(+)	69	Chassis Ground
20	Chassis Ground	70	Chassis Ground	20	Chassis Ground	70	Chassis Ground
21	Port 1 - B(+)	71	Port 2 - C(+)	21	Port 7 - B(+)	71	Port 8 - C(+)
22	Port 1 - B(-)	72	Port 2 - D(-)	22	Port 7 - B(-)	72	Port 8 - D(-)
23	Port 1 - C(-)	73	Chassis Ground	23	Port 7 - C(-)	73	Chassis Ground
24	Port 1 - D(+)	74	Chassis Ground	24	Port 7 - D(+)	74	Chassis Ground
25	Reserved	75	Port 5 - D(-)	25	28V	75	Port 11 - D(-)
26	GND	76	Port 5 - D(+)	26	Reserved	76	Port 11 - D(+)
27	SWITCH_MDC	77	GND	27	Chassis Ground	77	28VRTN
28	Port 0 - B(-)	78	Chassis Ground	28	Port 6 - B(-)	78	Chassis Ground
29	Chassis Ground	79	Port 4 - A(+)	29	Chassis Ground	79	Port 10 - A(+)
30	Chassis Ground	80	Chassis Ground	30	Chassis Ground	80	Chassis Ground
31	Chassis Ground	81	Chassis Ground	31	Chassis Ground	81	Chassis Ground
32	Chassis Ground	82	Chassis Ground	32	Chassis Ground	82	Chassis Ground
33	Chassis Ground	83	Port 5 - A(+)	33	Chassis Ground	83	Port 11 - A(+)
34	Chassis Ground	84	Port 5 - C(+)	34	Chassis Ground	84	Port 11 - C(+)
35	Reserved	85	Port 5 - C(-)	35	28V	85	Port 11 - C(-)
36	Reserved	86	Chassis Ground	36	28V	86	Chassis Ground
37	Chassis Ground	87	Chassis Ground	37	Chassis Ground	87	Chassis Ground
38	Chassis Ground	88	Port 4 - A(-)	38	Chassis Ground	88	Port 10 - A(-)
39	Chassis Ground	89	Port 4 - D(-)	39	Chassis Ground	89	Port 10 - D(-)
40	Port 2 - A(+)	90	Port 4 - D(+)	40	Port 8 - A(+)	90	Port 10 - D(+)
41	Chassis Ground	91	Chassis Ground	41	Chassis Ground	91	Chassis Ground
42	Port 3 - B(+)	92	Port 5 - A(-)	42	Port 9 - B(+)	92	Port 11 - A(-)
43	Port 3 - B(-)	93	Port 5 - B(+)	43	Port 9 - B(-)	93	Port 11 - B(+)
44	Port 3 - C(-)	94	Chassis Ground	44	Port 9 - C(-)	94	Chassis Ground
45	Port 3 - D(+)	95	Port 4 - B(+)	45	Port 9 - D(+)	95	Port 10 - B(+)
46	SWITCH MDIO	96	Port 4 - B(-)	46	Reserved	96	Port 10 - B(-)
47	GND	97	Port 4 - C(+)	47	Reserved	97	Port 10 - C(+)
48	Chassis Ground	98	Port 4 - C(-)	48	Chassis Ground	98	Port 10 - C(-)
49	Port 2 - B(-)	99	Chassis Ground	49	Port 8 - B(-)	99	Chassis Ground
50	Port 2 - A(-)	100	Port 5 - B(-)	50	Port 8 - A(-)	100	Port 11 - B(-)

3.4. Interface Port Details

3.4.1. Ethernet Ports

All connections in Table 3-1 that have a white background are Ethernet Port connections.

Table 3-2 indicates the appropriate wiring connections for the GES Ethernet ports relative to the available link speeds. Please note that MDI is the preferred connection choice. The GES and most modern Ethernet enabled electronics are capable of connecting using the MDIX scheme, but it is not advised.

Table 3-2: Ethernet Port Connections

GES Pin	RJ-45 Pinout P/N	MDI			MDIX		
		1000Base-T	100Base-T	10-Base-T	1000Base-T	100Base-T	10-Base-T
Port X - A(+/-)	1/2	BI_DA+-	TX+-	TX+-	BI_DA+-	RX+-	RX+-
Port X - B(+/-)	3/6	BI_DB+-	RX+-	RX+-	BI_DB+-	TX+-	TX+-
Port X - C(+/-)	4/5	BI_DC+-	Unused	Unused	BI_DC+-	Unused	Unused
Port X - D(+/-)	7/8	BI_DD+-	Unused	Unused	BI_DD+-	Unused	Unused

3.4.2. Serial and Programming Ports

All connections in Table 3-1 that have an Orange background are Serial Port connections.

The DEV1 serial port is a dedicated GES Management Processor Maintenance Port.

The DEV2 serial port was designed for future expansion as an in-band Ethernet to Serial Bridge.

The SWITCH_MDIO port is the External Programming Port.

Table 3-3 indicates the appropriate wiring connections for the DEV1 and DEV2 serial ports.

Table 3-3: Serial Port Connections

Signal	Direction	Type	Connects	Notes
TX_TO_DEVX	Output	RS-232	DB9-2	
RX_FROM_DEVX	Input	RS-232	DB9-3	
GND	Reference	RTN	DB9-5	J1-26,77

The Programming Port connections described in Table 3-4 are for use with the Aeronix GES Programming Fixture, part number AE100937-001.

Table 3-4: Programming Port Connections

Signal	Direction	Type	Connects	Notes
MVL_CPU_MDC	Input	TTL	Programming Fixture	
MVL_CPU_MDIO	Bidirectional	TTL	Programming Fixture	
GND	Reference	RTN	Programming Fixture	J1-47

3.4.3. Input Power

The connections shown in Table 3-1 with a Red background are Power Connections. At least two of the +28V pins and two of the 28VRTN pins must be connected to the power source.

The input power requirements are as specified in MIL-STD-704A:
Aircraft, 28 VDC, Category B (curves 2 &3 of Fig. 9)

During normal operations the maximum power draw of the GES is 22 watts.

4. Port Details

4.1. Serial Ports

There are two serial ports associated with the Management Processor, DEV1 and DEV2. Both ports are RS-232 compatible and operate only at:

- 115.2K baud
- 1 Stop Bits
- No Parity
- No Flow Control

The DEV1 port supports out-of-band configuration management of the GES.

The DEV2 serial port was designed for future expansion as an in-band Ethernet to Serial Bridge. It operates only with the settings indicated above. See section 5.2 for details.

These capabilities include:

- Direct control of the Switch IC's SMI bus between the Management Processor (MP) and the External SMI connections
- Select between Switch IC 0 and 1 for SMI control (MP or External)
- Management and Loading of Switch IC configuration files
- GES Commanded Reset

4.2. External Programming Port

The External Programming Port is used for programming the internal registers of the Switch ICs and their associated PHY's. This interface is used by the GES Programming Fixture.

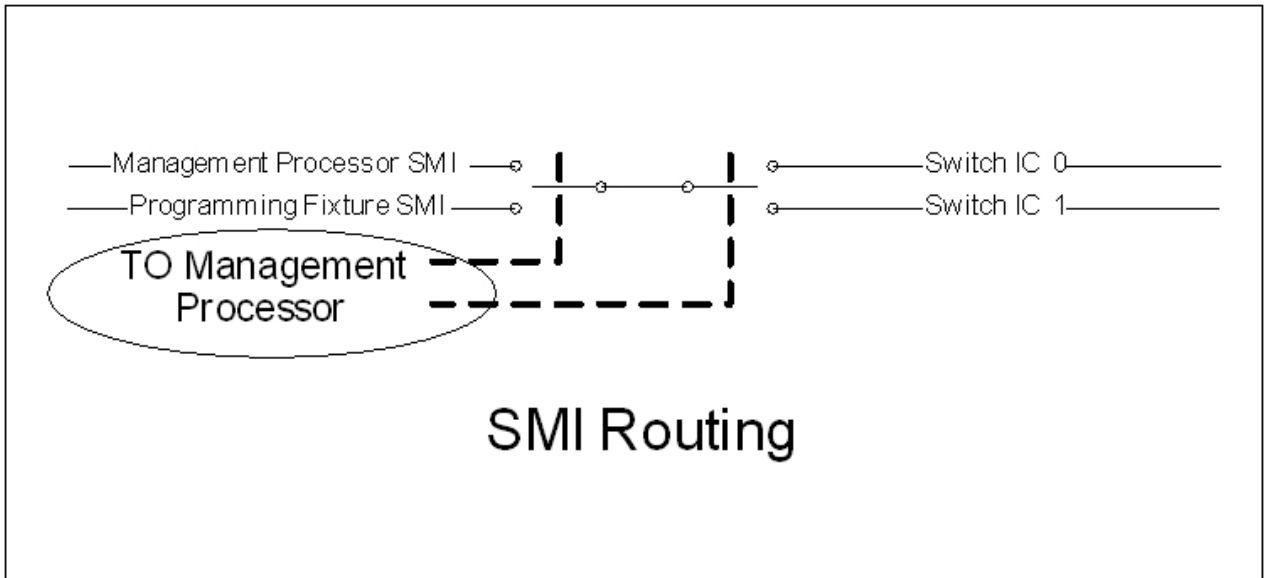

At power-up, the Management Processor SMI programs the Switch IC's with their initial configuration which gives the GES its base functionality.

With the addition of software to the Management Processor, any functionality that is native to the Switch IC's or PHY's can be performed. This includes the capabilities of the Marvell software when used with the Programming Fixture.

The GES Programming Fixture contains a Marvell designed USB to SMI interface CCA and associated software. Connection of the Programming Fixture to the GES will allow the user to perform any Switch IC or PHY configuration changes that are supported by the Marvell software.

With the use of the Programming Fixture and the Marvell Software, custom configuration files can be generated. These configuration files can then be programmed into the GES and configured to load at startup, or after a commanded reset through the maintenance port.

5. Command Line Interface

The GES Command Line Interface (CLI) is used for out-of-band control of the GES. It provides the ability to customize configurations and status monitoring.

A GES Programming Fixture is not required to use the CLI. The GES Programming Fixture allows register level switch IC and PHY control which aids in developing custom GES configurations. The CLI is used to import these custom configurations.

5.1. Required Hardware

To interact with the STR9 CPU, the following hardware is required:

- The GES Programming Fixture, Part Number AE100937-001 (Optional)
- Power supply (included with the Programming Fixture)
- Gigabit Ethernet Switch, Part Number AE100922-001
- Computer with Terminal Emulation software (i.e.: TerraTerm under Windows)

The GES Programming Fixture provides access to the two serial ports, the MII interface, as well connections to supply power. The MII interface is used to configure the two Marvel 88E6131 switches within the GES.

5.2. Serial Port Setup

Serial port setup is 115,200 Baud with N81 and no hardware or software handshaking. The command system is tied to DEV1.

The second UART (DEV2) will reply to an input character with a message string “Saw a NN on port 1\n”, where NN is a hexadecimal representation of the input character.

5.3. Prompt

The command line interface displays a prompt before accepting any new commands.

This prompt displays important information and is defined as follows:

```
GES(A;sB;rs=C;rp1=D;rp2=E;temp:FC)>
```

Where:

A is ‘i’ indicating internal control or ‘x’ for external control.

B is ‘0’ indicating Switch 0, or ‘1’ indicating Switch 1.

C is ‘0’ indicating both switches are in Reset, or ‘1’ indicating switches not in Reset.

D is ‘0’ indicating the first group of 3 external Phys are in Reset, or ‘1’ indicating they are not in Reset.

E is ‘0’ indicating the second group of 3 external Phys are in Reset, or ‘1’ indicating they are not in Reset.

F is the internal temperature of the GES in degrees Celsius

5.4. Menus

5.4.1. How the menus work

All menu selections require a single character to be input. There is no need to enter a carriage return.

5.4.2. Main Menu

```
Main menu:
h   get help (show this list)
0   set control to switch 0
1   set control to switch 1
i   set control of switches to Internal
x   set control of switches to External
w   initialize switches
g   display switch global control reg
s   display statistics
m   mii command
r   go to reset menu
c   go to configuration menu
```

5.4.2.1. 'h' – get help (show this list)

This selection displays the main menu selections. Additionally, the help command displays the current software version.

5.4.2.2. '0' – set control to switch 0

MII commands are routed to just one of the two switches at a time (whether the MII commands are coming from the onboard CPU or the external MII interface). This sets the control path to route MII commands to switch 0.

5.4.2.3. '1' – set control to switch 1

This sets the control path to route MII commands to switch 1.

5.4.2.4. 'i' – set control of switches to Internal

MII commands can originate with the onboard CPU or from an external connection. This selection chooses internal CPU as the source for MII commands.

5.4.2.5. 'x' – set control of switches to External

This selection chooses the external connection as the source for MII commands.

5.4.2.6. 'w' – initialize switches

Sends MII commands to initialize both switches to form what the external world sees as a single 12 port switch. Note: This command requires the control be set to Internal to work properly.

5.4.2.7. 'g' – display switch global control reg

Display the contents of the Global Control register of the selected switch along with contents of the Global Status register. Also displayed is a table showing

Phy Control, Phy Status, Port Control, and Port Status of the three internal Phys.
Note: This command requires Internal control.

5.4.2.8. 's' – display statistics

Display simple statistics relating to CPU operation. This displays interrupt counts for I2C, UART0, UART1, and Ethernet.

5.4.2.9. 'm' – mii command

Display results of MII read commands for the first four registers of Phy Device 0 through 0x1D (hex). This command is useful mostly for showing activity on the MII interface.

5.4.2.10. 'r' – go to reset menu

Change to the Reset Menu (you can get back to the main menu by hitting 'b').

5.4.2.11. 'c' – go to configuration menu

Change to the Configuration Menu (you can get back to the main menu by hitting 'b').

5.4.3. Reset Menu

5.4.3.1. Menu Overview

Reset menu:
h get help (show this list)
s toggle reset switch
1 toggle reset phy 1
2 toggle reset phy 2
b back to main menu

5.4.3.2. 'h' – Help

This selection displays the reset menu selections. Additionally, the help command displays the current software version.

5.4.3.3. 's' – toggle reset switch

This command toggles the reset line going to both switch chips.

5.4.3.4. '1' – toggle reset phy 1

This command toggles the reset line going to the first group of external Phy chips.

5.4.3.5. '2' – toggle reset phy 2

This command toggles the reset line going to the second group of external Phy chips.

5.4.3.6. 'b' – back to main menu

Return to the main menu.

5.4.4. Configuration Menu

5.4.4.1. Menu Overview

```
Configuration menu:
h   get help (show this list)
0   set control to switch 0
1   set control to switch 1
i   set control of switches to Internal
x   set control of switches to External
2   initialize I2C interface
s   show switch's configuration
e   erase current switch's configuration
u   upload current switch's configuration
p   program switches
b   back to main menu
```

5.4.4.2. 'h' – get help (show this list)

This selection displays the configuration menu selections. Additionally, the help command displays the current software version.

5.4.4.3. '0' – set control to switch 0

MII commands are routed to just one of the two switches at a time (whether the MII commands are coming from the onboard CPU or the external MII interface). This sets the control path to route MII commands to switch 0. This is the same command that is present in the main menu, but it is repeated here for convenience.

5.4.4.4. '1' – set control to switch 1

This sets the control path to route MII commands to switch 1. This is the same command that is present in the main menu, but it is repeated here for convenience.

5.4.4.5. 'i' – set control of switches to Internal

MII commands can originate with the onboard CPU or from an external connection. This selection chooses internal CPU as the source for MII commands. This is the same command that is present in the main menu, but it is repeated here for convenience.

5.4.4.6. 'x' – set control of switches to External

This selection chooses the external connection as the source for MII commands. This is the same command that is present in the main menu, but it is repeated here for convenience.

5.4.4.7. '2' – initialize I2C interface

I2C is not supported in this release.

5.4.4.8. 's' – show switch's configuration

This command displays the stored configuration words that are sent to each switch after it is reset and set up to be part of what externally looks like a single

12 port switch. The format utilized for the words is derived directly from the Marvel description of how the switch is loaded via EEPROM.

5.4.4.9. ‘e’ – erase current switch’s configuration

The configuration is stored in EEPROM within the STR9 CPU onboard the GES. In order to write a new configuration the old configuration must first be erased.

5.4.4.10. ‘u’ – upload current switch’s configuration

This command allows for the loading of a new configuration to the currently selected switch. This supports a terminal emulator transfer of the configuration file using ASCII upload. The terminal emulator should be set up to delay 40 milliseconds between characters.

Note: The last word is FFFF which indicates the load is complete.

5.4.4.11. ‘p’ – program switches

This command will cycle both switches through Reset, do the initial programming to configure switches to appear externally as a single 12 port switch, and then it will apply the additional configuration data stored in EEPROM by the “upload current switch’s configuration” command. This command overrides internal/external selection to be internal and performs the complete initialization and configuration of both switches.

5.4.4.12. ‘b’ – back to main menu

Return to the main menu.

5.5. Example

This is an example of the interaction with the GES command line interface. The following actions are performed:

- Select internal control of the switches
- Change to the configuration menu
- Show the current extra configuration of the two switches
- Update the configuration of switch 0
- Show the new configuration of the two switches
- Program the two switches with the new configuration

Note: characters input by the user are in **bold**.

```
GES(x;s0;rs=1;rp1=1;rp2=1;temp:27C)>i
GES(i;s0;rs=1;rp1=1;rp2=1;temp:27C)>c
Help
GES Software Version: 2.2
Compiled on: Dec 23 2008 at 11:20:05
    Configuration menu:
Cmd  Description
h    get help (show this list)
0    set control to switch 0
1    set control to switch 1
I    set control of switches to Internal
x    set control of switches to External
2    initialize I2C interface
```

```
s    show switch's configuration
e    erase current switch's configuration
u    upload current switch's configuration
p    program switches
b    back to main menu
GES(i;s0;rs=1;rp1=1;rp2=1;temp:27C)>s
showSwitchConfigs
SWITCH 0 Configuration Words:

SWITCH 1 Configuration Words:

GES(i;s0;rs=1;rp1=1;rp2=1;temp:27C)>u
uploadSwitchConfig
Use terminal emulation program to upload text file
Containing the switch modifications.
(use cntl-c to abort)
8204 0177 700c 7c10 00d9 7c00 b100 7c04 0021 7c00 1340 8214
c403 8200 0085 ffff
Received final word (0xFFFF)
Words Received:
8204 0177 700c 7c10 00d9 7c00 b100 7c04 0021 7c00 1340 8214
c403 8200 0085
Programming Flash
.....
GES(i;s0;rs=1;rp1=1;rp2=1;temp:27C)>s
showSwitchConfigs
SWITCH 0 Configuration Words:
8204 0177 700c 7c10 00d9 7c00 b100 7c04 0021 7c00 1340 8214
c403 8200 0085

SWITCH 1 Configuration Words:

GES(i;s0;rs=1;rp1=1;rp2=1;temp:27C)>p
GES(i;s0;rs=1;rp1=1;rp2=1;temp:27C)>
```

6. Switch Management Capabilities

The GES is based on two Marvell 88E6131 eight port 10/100/1000 QoS Ethernet Switch ICs. The data sheet for the Marvell parts can be accessed at www.marvell.com. Access to the data sheet requires creating an account on the Marvell web site. Aeronix cannot supply these data sheets as they are proprietary to Marvell.

The data sheets are only necessary if the creation of custom configurations of the GES are desired. The following list is a sub-set of the capabilities of the Switch IC's:

- Egress tagging/untagging - selectable per port or by 802.1Q VLAN ID
- Port Based VLANs - supported in any combination or 802.1 VLAN support for 4096 VIDs
- Port States and BPDU handling for spanning tree
- 802.1X Source MAC address authentication
- Quality of Service - switch architecture provides non-blocking switching in all traffic environments
- Link Aggregation (802.3ad) - allows two or more links to be trunked to increase the total bandwidth and provide a fail safe if one of the links fails
- A high speed, non-blocking, QoS switch fabric with support for four traffic classes based on:
 - Port
 - IEEE 802.1p
 - IPv4's TOS or Diff-Serv
 - IPv6's Traffic Class
 - 802.1Q VID
 - DA MAC address
 - SA MAC Address
- Back-pressure flow control on half-duplex ports
- Pause-frame flow control on full-duplex ports
- Lookup engine supports 1024 MAC address entries with learning and aging
- Auto-MDI/MDIX and polarity correction

All of these features can be accessed thru the Aeronix GES Programming Fixture (P/N AE100937-001).

The Management Processor in the GES is an ARM9 running at 96 MHz. It is directly connected to a dedicated in-band ethernet port on the Switch IC's. It is capable of running a TCP/IP stack so that it can be an active participant on a network serviced by the GES.

Aeronix can create custom loads for this processor that will allow increased GES management functionality and/or customer defined custom applications that would be hosted on this processor. This processor, after startup, only services the Maintenance port, thus it is only lightly loaded.

7. Hardware Mounting

The GES weighs less than 3 pounds and is mounted via its four 10-32 captive screws.

The minimum required screw thread depth on the mounting surface is 0.50 inches.

The rectangular mounting pattern for the attachment points is 3.55" x 7.71" as shown in Figure 8-1.

The overall external dimensions of the GES are 8.25" L x 5.15" W x 1.38" H.

8. Indicators

The GES has one green LED on the front panel labeled PWR. This LED is illuminated when input power is applied to the GES.

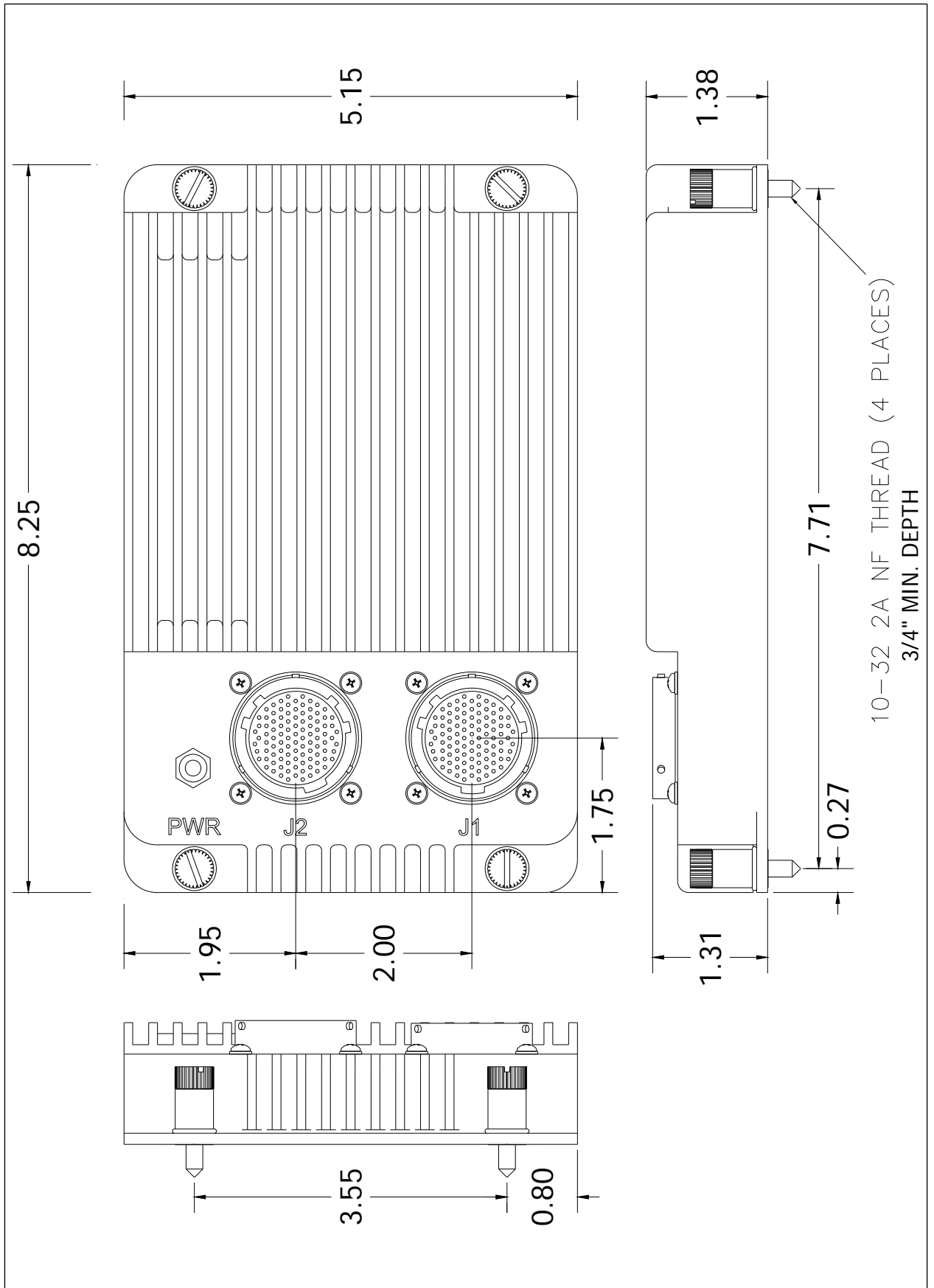

Figure 8-1: External Dimensions

9. Qualifications

MIL-STD-810	Environmental Test Description
Altitude	Method 500.4, Proc. I & II
Low Temperature	Method 502.4, Proc. I & II
High Temperature	Method 501.4, Proc. I & II
Vibration	Performance per A10 Req's
Vibration	Endurance A10 Req's
Vibration	Gunfire per A10 Req's
Shock	Method 516.5, Proc. I – 20g 11ms
Shock	Method 516.5, Proc. V – 40g 11ms
Shock	Method 516.5, Proc. VI – Bench
Salt Fog	Method 509, Proc. I
Rain	Method 506.4, Proc. III
Explosive Atmosphere	Method 511.4, Proc. I
Temperature Shock	Method 503.4, Proc. I
Acoustic Noise	Method 515, Proc. I
Acceleration	Method 513.5, Proc. I

MIL-STD-704A
28-volt DC source as specified in MIL-STD-704A aircraft 28V DC, Category B.
Curve 2 and Curve 3 of Figure 9 of MIL-STD-704A. (Includes 50mSec total power dropout)

MIL-STD-461E	EMI / EMC Test Description
CE102	Conducted Emissions, Power Leads (10KHz-10MHz) Figure CE102-1, Basic Curve
CS101	Conducted Susceptibility, Power Leads (30Hz-150KHz) Figure CS101-1, Curve #2
CS114	Conducted Susceptibility, Bulk Cable Injection, Table VI, Air Force Aircraft Internal (10KHz-200MHz Curve #3)
CS115	Conducted Susceptibility, Bulk Cable Injection, Impulse Excitation, Figure CS115-1
	Cables: J1, J2, 28VDC, 28VDC and Return
CS116	Conducted Susceptibility, Damped Sinusoidal Transients, Cables and Power Leads (10KHz-100MHz) I _{max} = 10 Amps
RE102	Radiated Emissions, Electric Field (10KHz-18GHz) Figure RE102-3 (<25 meters Nose to Tail)
RS103	Radiated Susceptibility, Electric Field (2MHz-1GHz 20V/m and 1-18GHz 60 V/m)

10. Warranty

- a. Seller expressly warrants that all goods and services shall be free from defects, shall be of good materials and workmanship, and shall conform to applicable specifications, drawings, samples, and performance specifications.
- b. The Seller warranty shall remain in effect for a period of one year after the item is shipped, or the service is completed, from or by the Seller.
- c. In the event Seller is required to replace or correct any component of any item, the running of the warranty period for the items of which the defective component is a part shall be suspended from the date Seller receives the item until the date the item is replaced or corrected, and this warranty shall apply to such replacement or corrected items furnished for the unexpired portion of the warranty period.
- d. Seller shall not be responsible for any liabilities, loss, costs, damages, and/or expense resulting from any breach of any, or all, of Seller's warranties, express, or implied. Seller shall not be responsible for any cost of removing such items from property, equipment, or products, and/or any additional costs of disassembly, fault isolation, failure analysis, reinstallation, reinspection, retesting in which such items have been incorporated and/or transportation to or from the Seller.

The GES does not contain any user serviceable parts. Any modification or use other than consistent with the intended design shall void the warranty. Owner must contact Aeronix at (321) 984-1671 and be issued a Return Material Authorization (RMA) number before returning a unit for warranty repair.

11. Accessories and Services

Aeronix offers an extensive line of Engineering Services including the creation and implementation of custom management configurations for the GES.

Visit the Aeronix web site at www.Aeronix.com for additional information about our products and services.

The Aeronix GES Programming Fixture, part number AE100937-001, can be purchased separately.



1775 West Hibiscus Blvd, Suite 200
Melbourne, FL 32901
(321) 984-1671
WWW.Aeronix.com

Copyright Aeronix, Inc. 2009
